

HANDOUT by GraffitiDiplomacy.Com

HOW TO DRAW 3-D LETTERS : Method 1

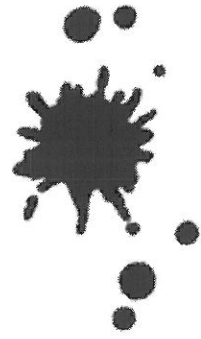

- Step 1. Draw a block letter "A" on a sheet of paper.
- Step 2. Put a second sheet of paper on top and trace the "A" with a pencil.
Now move the top paper a little bit in any direction and trace the "A" again.
- Step 3. Erase the overlapping lines.
- Step 4. Your "A" should look like this, with one "A" behind the other.
- Step 5. Draw lines to connect the corners.
- Step 6. Color in the 3-D.

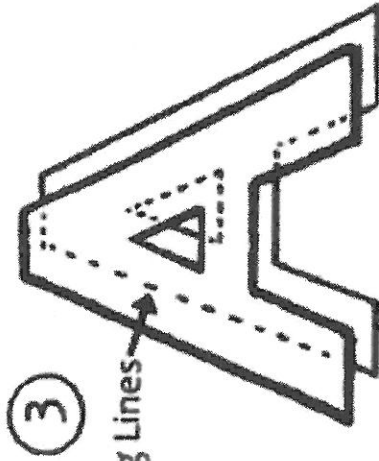
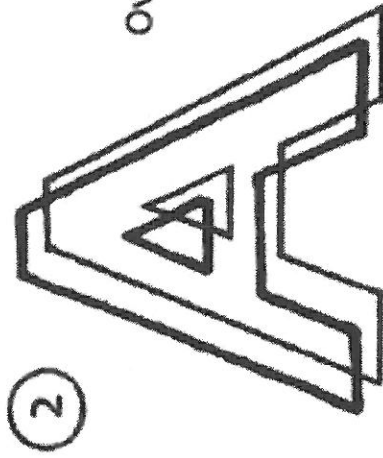
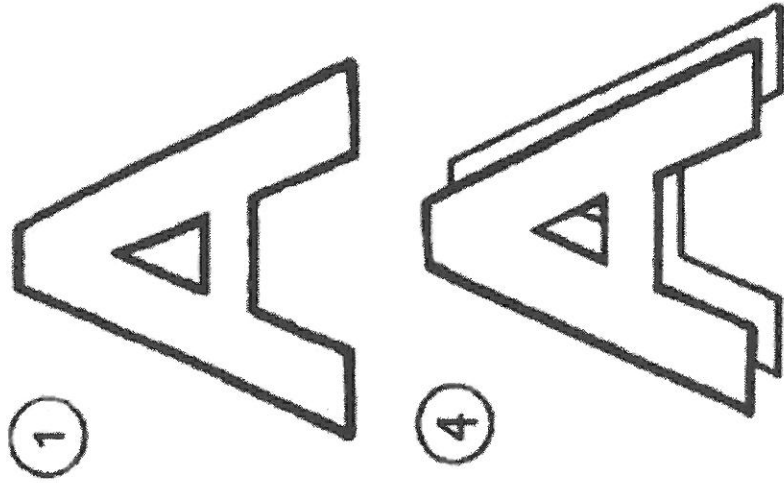

Overlapping Lines

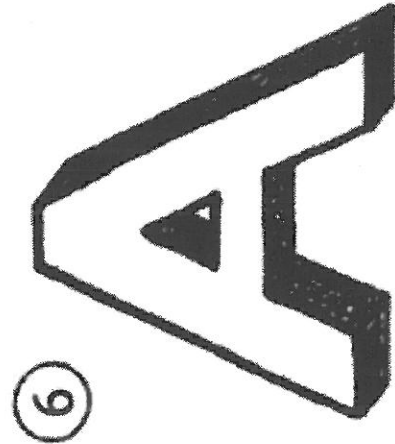
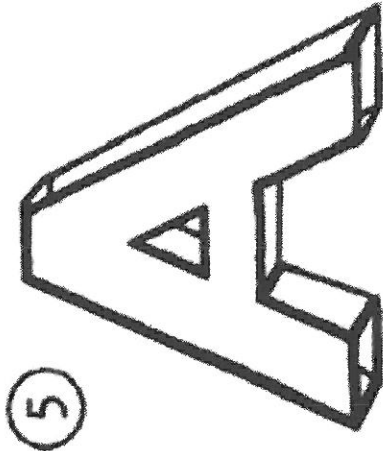

HANDOUT by GraffitiDiplomacy.com

HOW TO DRAW 3-D Letters: Method 2

Step 1. First draw a word with block letters.

You can add serifs (feet) and corners to make it more interesting.



Step 2. Now from the bottom of each letter, and every corner on the outside of the letters, draw a straight line directly downwards. Each line should be the same length.



Step 3. Now you are going to connect the lines to form the 3-D. Draw a straight line from the tip of each downward line to the line directly next to it. Follow the shape of the letter.

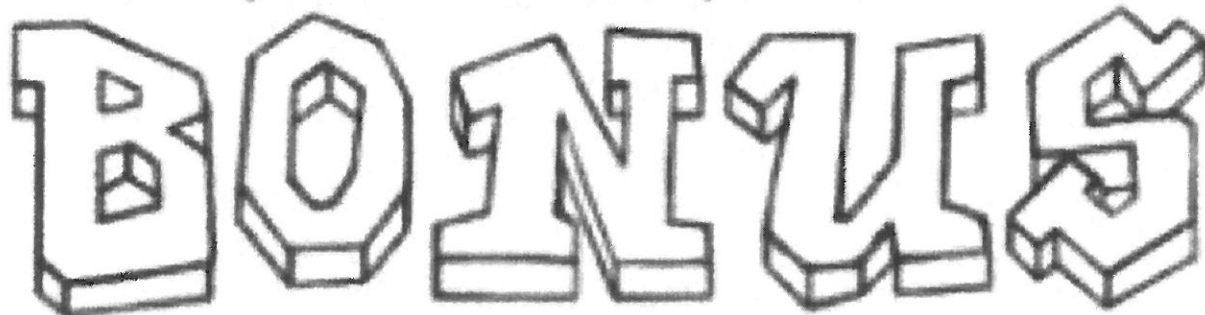

Step 4. Color in the 3-D.



HANDOUT by GraffitiDiplomacy.com

How To Draw 3 Dimensional Letters: Method 3 - Vanishing Point

Letters on a page look flat. That is called "2 dimensional".

You can give your letters depth by drawing the sides of the letter, as well as the front. Even though you're still drawing just lines on a piece of paper, your letters will have the "illusion" of depth. They will look "3 dimensional", like they can jump off the paper at you. This is called drawing in "perspective".

In a "3 dimensional" drawing, a "vanishing point" is a point at which all imaginary lines of "perspective" converge. You can place a vanishing point anywhere on your drawing that you wish.

Draw lines from the corners of your letter to the vanishing point.

Then draw a line parallel to the edge, following the shape of the letter.

VANISHING POINT

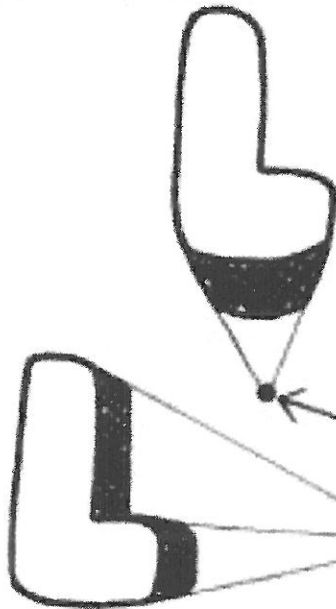
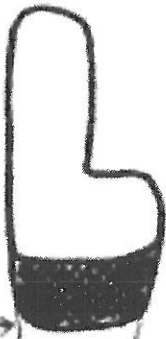

VANISHING POINT

Why is it called a vanishing point? Because things look smaller as they get further away and eventually become a teeny, tiny little dot in the distance.

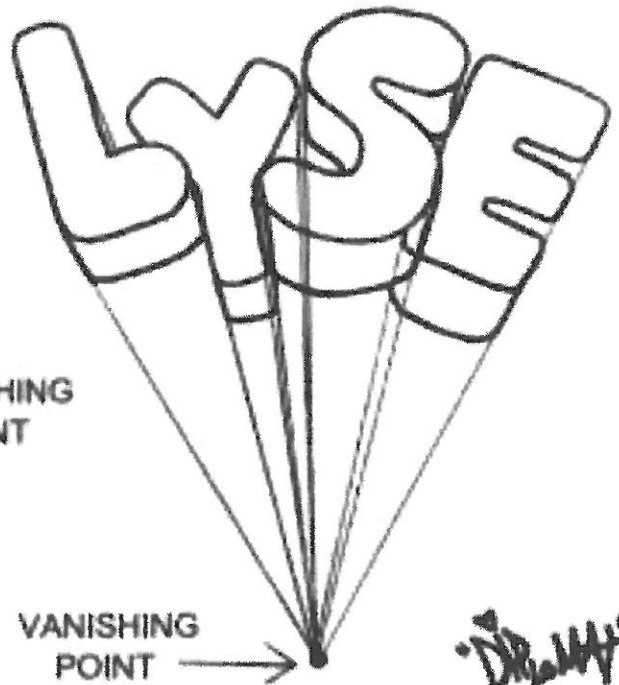

VANISHING POINT

"DRAMA"

STEP 1
Draw an "L"
with a pencil.

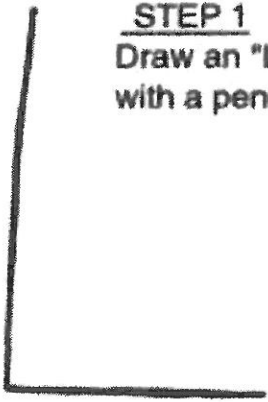

STEP 2
Draw bars
around the lines.

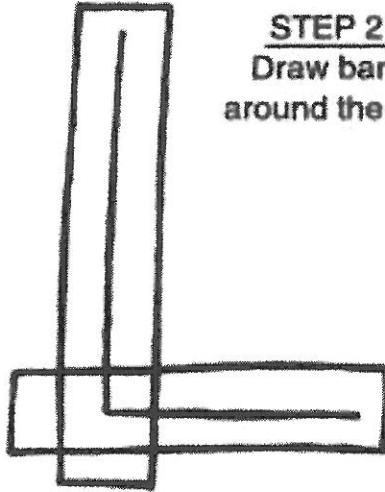

STEP 3
Erase the
inside lines.

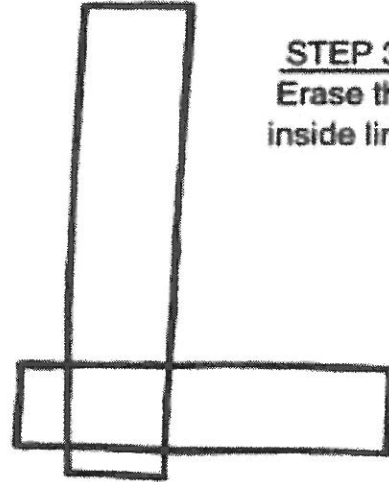

STEP 4
Bend the bars.

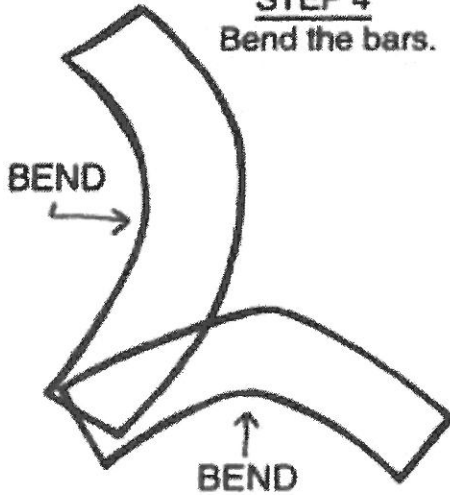

STEP 5
Draw around
the outline
and erase
inside lines.

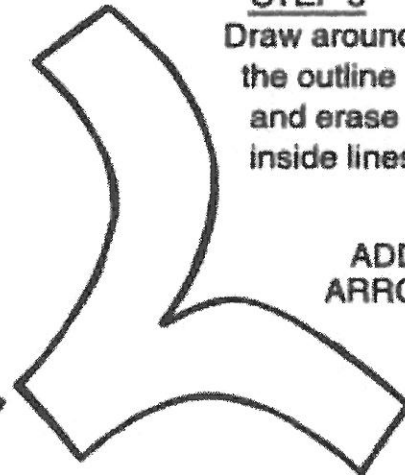

ADD →
ARROW

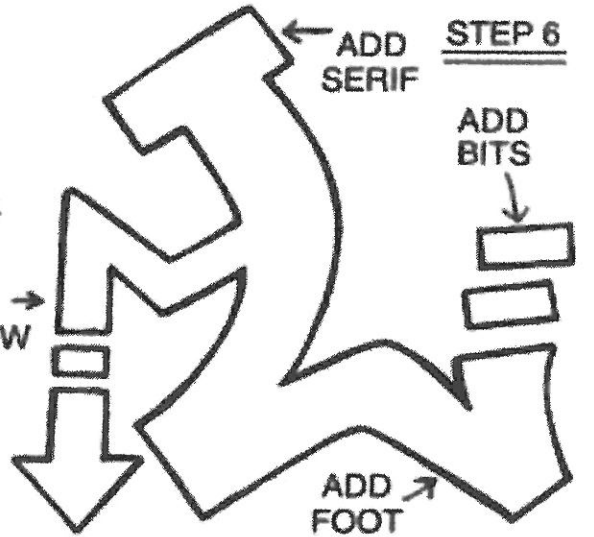

STEP 6

← ADD
SERIF

ADD
BITS

ADD ↘
FOOT

HANDOUT by GraffitiDiplomacy.com

HOW TO BUILD A WILDSTYLE "N" USING BARS

Step 5.

Add serifs or "feet" to the ends of the letter at the bottom, and an extension near the top.

Step 6.

Stretch them out as far as you can. Form them into arrows and extra pieces as shown. Add a curving arrow coming out of the side.

Step 1. Draw a capital "N".

Step 2. Draw bars over the lines to thicken it.

Step 3. Now bend the bars. all in a similar direction.

Step 4. Draw the outline of the letter, smoothing over all the edges.

Step 7.

Slice the arrows and extensions and separate them into bits.

Step 8.

Add 3-D.

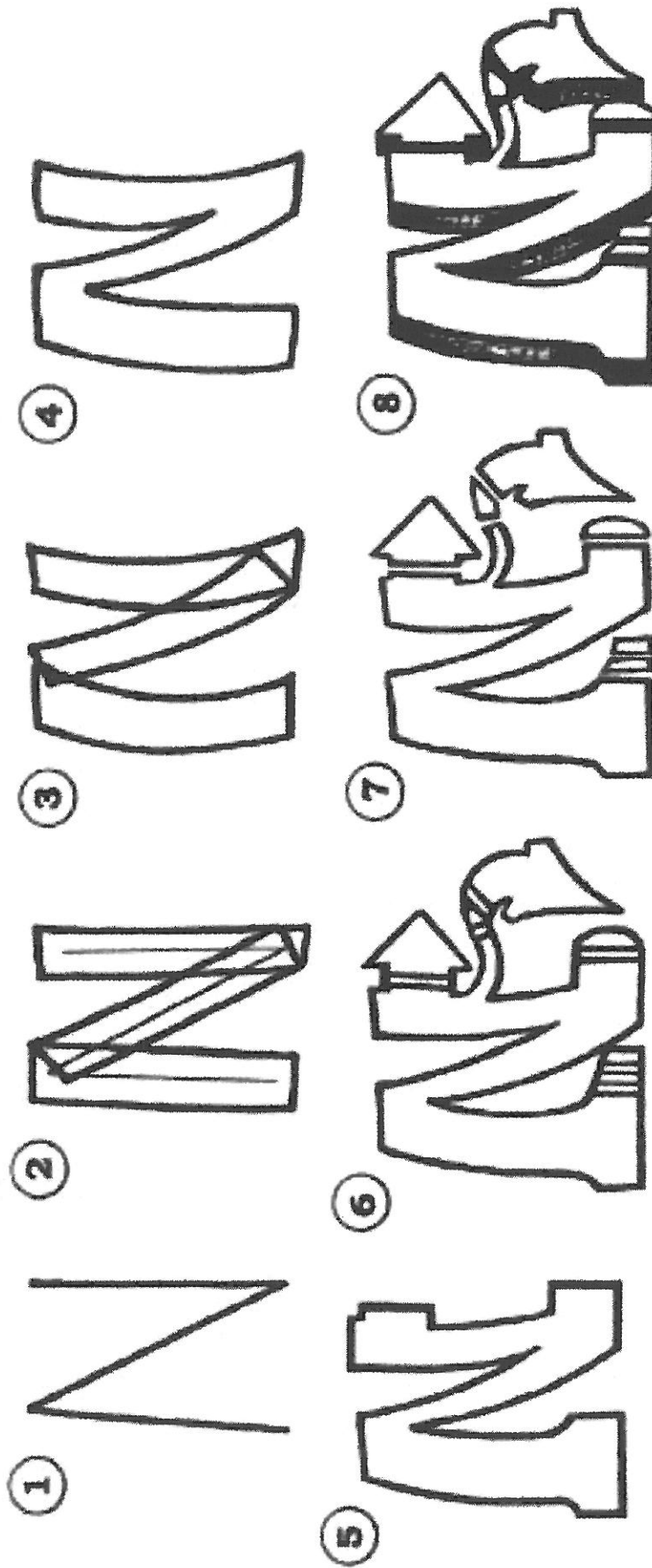



HOW TO DRAW A WILDSTYLE "H"

- by Graffiti Diplomacy

Step 1. Start by drawing an "H" with a pencil. You should have 2 vertical strokes and one horizontal stroke.

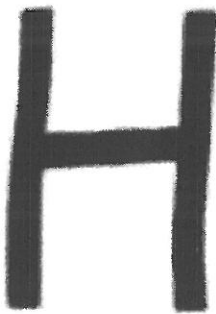

Step 2. Draw a bar around each stroke. Overlap the edges of the bars.

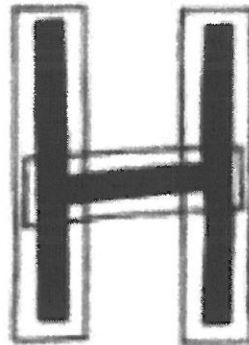

Step 3. Erase all of the inside guidelines.

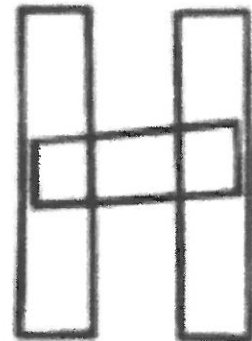

Step 4. Now bend the 2 vertical bars and the horizontal bar.

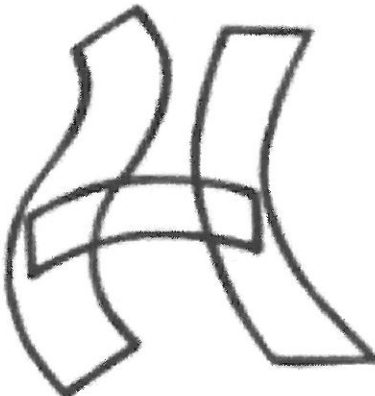

Step 5. Draw 4 small bars at the top and bottom ends of the vertical bars to form serifs. Then draw a long, curvy arrow extending off the bar on the right side.



Step 6. Draw a dark line all around the outside edges. Draw 2 small bits. Erase all of the inside guidelines. This is your finished Wildstyle letter.

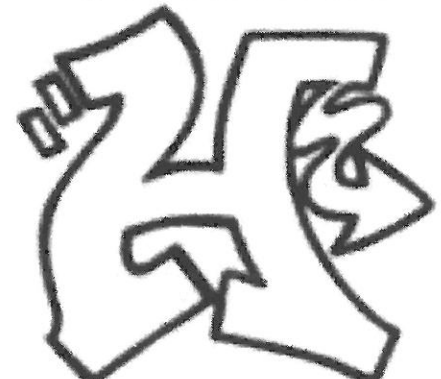

For more free graffiti drawing lessons and free graffiti coloring pages go to © www.graffitidiplomacy.com

BUBBLE LETTERS

- 1) Lightly draw large letter.
- 2) Draw line all the way around the letter and inside (uniform width).
- 3) Optional: Erase inside line.



1.



2.

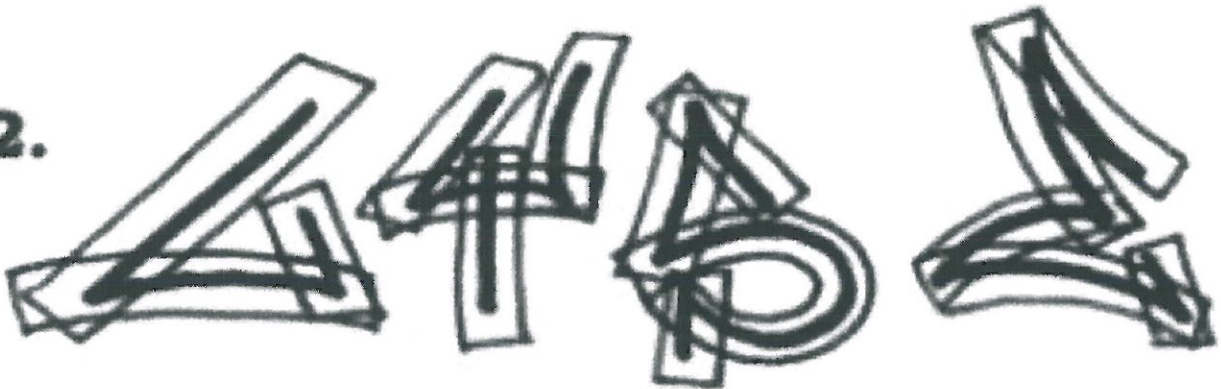

3.



4.



ZAP!

POW!

BAM!

BANG!

iStock
by Getty Images

RETRO COMIC BOOK EFFECT COLLECTION



cosiphotos

cosiphotos

PLOM! **BLAF!?!**
KNOCK **!!?+**

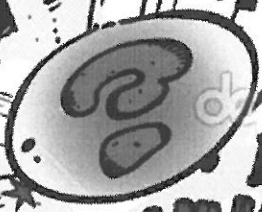

KNOCK!
BOING!



BOOMM!!

BAM!

HA HA HA HA HA HA
HA HA HA HA HA HA
HA HA HA HA HA HA
HA HA HA HA HA HA

KRASH



BOOM!



BAM! **SPONG!**

CRASH! **PLOP**

BOOM!

WHAMM!



cosiphotos

cosiphotos

cosiphotos

cosiphotos

cosiphotos









dreamstime.com

